



MODEL "A"

Instruction  
Book

*Ford Motor Company*

Copyrighted 1928  
by  
Ford Motor Company  
All rights reserved

*Reprinted with permission of*  
FORD MOTOR COMPANY  
by  
POLYPRINTS

## FOREWORD

This book contains information necessary to the proper handling and care of your Ford car. Read it carefully—particularly the instructions on lubrication, the cooling system, care of battery, etc., which are absolutely necessary to economical and satisfactory operation.

Your car is a splendid piece of machinery. If properly cared for, it will give you years of satisfactory service at little cost.

When repairs are needed, we recommend having the work done by an authorized Ford dealer. They are provided with special service equipment. Furthermore they are interested, more than any one else, in your personal satisfaction with the car.

Let experienced mechanics make repairs or adjustments. Your car is too valuable a piece of machinery to place in unskilled hands.

Expert workmanship is just as essential in servicing your car as it is in building it.

## IMPORTANT

When repairs or replacements are necessary, it is important that you get genuine Ford parts. This is assured when you take your car to an authorized Ford dealer.

Imitation or counterfeit parts of inferior quality are being made and sold as "Ford Parts." Avoid their use by dealing with an authorized Ford dealer.

## SPECIFICATIONS AND LICENSE DATA

<b>Engine</b>	Type of engine . . . . . 4 cylinder Cylinder bore . . . . . $3\frac{7}{8}$ inch Stroke . . . . . $4\frac{1}{4}$ inch Horse Power . . . (S. A. E. rating) 24.03
<b>Transmission</b>	Selective sliding gear type, three speeds forward and reverse.
<b>Clutch</b>	Single plate dry disc.
<b>Brakes</b>	Four wheel internal expanding service brakes operated by the foot brake pedal. Also an emergency or parking brake on both rear wheels operated by the emergency brake lever. The emergency brakes are entirely separate and distinct from the four wheel service brakes. Total braking surface $225\frac{1}{2}$ sq. inches.
<b>Steering Gear</b>	$\frac{3}{4}$ Irreversible, worm and sector type, ratio $11\frac{1}{4}$ to 1.
<b>Oiling System</b>	Engine lubricated by gear pump, splash and gravity feed. Oil pan capacity 5 quarts.
<b>Cooling System</b>	Pump and thermo-syphon. Capacity, 3 gallons.
<b>Gasoline Tank</b>	Capacity, 10 gallons.
<b>Rear Axle</b>	Three-quarter floating type. Torque tube drive. Spiral bevel drive pinion and gear.
<b>Tires</b>	21 x 4.50 Balloon.
<b>Wheel Base</b>	$103\frac{1}{2}$ inches.
<b>Turning Radius</b>	17', circle 34'.
<b>Tread</b>	56 inches.
<b>Road Clearance</b>	$9\frac{1}{2}$ inches.

### ENGINE NUMBER

The engine number is stamped on the left side of the cylinder block just above the cylinder inlet connection. The engine number is also the serial number of the car.

## THE CAR AND ITS OPERATION

### *Filling the Radiator*

Before starting the car, see that the radiator is filled with clean, fresh water. The cooling system holds approximately three gallons. In winter, use an anti-freeze solution (procurable from any Ford dealer).

As the proper cooling of the engine is dependent upon the water supply, it is important particularly with a new car to see that the radiator is kept well filled.

### *Filling the Gasoline Tank*

The tank has a capacity of ten gallons. The gasoline gauge on the instrument panel indicates the amount of gasoline in the tank.

Gasoline can be drained from the tank by opening the petcock in the sediment bulb located on the engine side of the dash. The screen in the gasoline tank filler neck should occasionally be removed and cleaned. **IMPORTANT:**—After cleaning be sure to replace the screen screwing it down in place. Also see that the small vent hole in the gasoline tank cap does not become clogged.

### *Proper Oil Level*

Before starting the engine, make sure there is a sufficient supply of high-grade engine oil in the oil pan. If there is not enough oil, more should be added through the breather pipe located at the left side of the engine (a metal cap covers it). Five quarts of oil is the amount required in the oil pan.

To determine the correct oil level, use the indicator located on the left side of the engine just to the rear of the breather pipe (see Fig. 1), as follows:

Pull out the indicator—wipe it off—re-insert the indicator and again remove it.

The mark made by the oil indicates its level. When the oil reaches the point marked "F" on the indicator, it is at the proper level. Under no circumstances should the oil level be permitted to get below the point marked "L" as any attempt to run the engine with too little oil may seriously damage the parts.

When replacing the oil level indicator, see that both the short and long ends of the indicator enter the opening in the crankcase and push the indicator all the way down (see Fig. 1). Failure to insert both ends into the opening permits oil to leak out.



Figure 1

### *Before Starting the Engine*

Be sure the gear shift lever is in neutral position, i. e., the position in which it can be moved freely from side to side.

Advance the throttle lever located under the steering wheel (right hand side) about three notches, or until the accelerator pedal moves slightly downward.

Pulling down the throttle lever or pressing on the accelerator pedal, controls the quantity of gas entering the cylinders, and regulates the speed of the engine.

Place the spark lever (left hand) at the top of the quadrant (the notched quarter-circle on which the lever is operated). This is the retard position. The spark lever regulates the timing of the spark which explodes the gas in the cylinders.

Always retard the spark lever when starting your car. Starting the engine with the spark advanced may cause the engine to kick back, and damage the starter parts. After the engine is started, advance the spark lever about half way down the quadrant.

### *Theft Proof Lock*

The Ford type electro-lock used in the ignition switch is a combination switch and theft proof lock affording full protection for the car and meeting the exacting requirements of the underwriters as regards theft insurance.

To unlock the electro-lock, simply insert the switch key into the ignition switch and turn the key to the right. This releases the cylinder of the lock which snaps forward and closes the ignition circuit. When the cylinder is released the engine can be started in the usual manner, **and the switch key withdrawn from the lock.** To shut off the engine, push in on the cylinder of the lock until it snaps back in the lock position. Be sure that it stays in. This shuts off the ignition and locks the car.

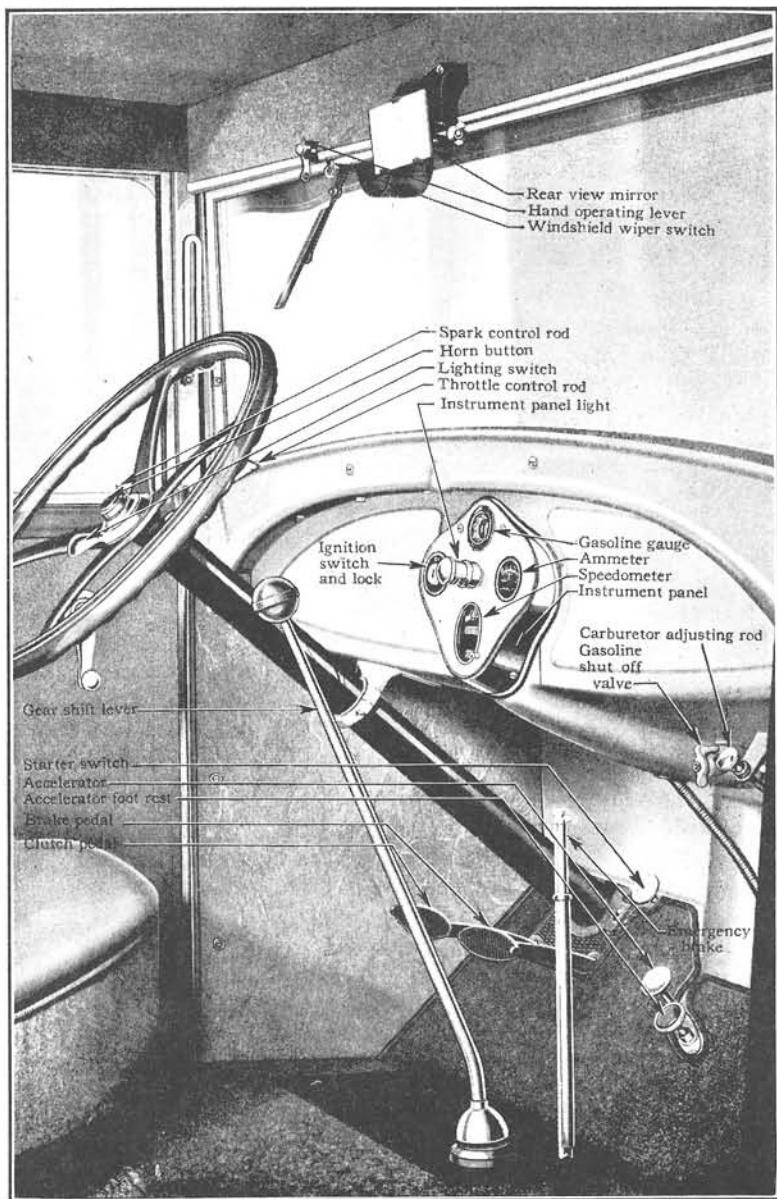

**Figure 2**  
**Instruments and Control Levers**

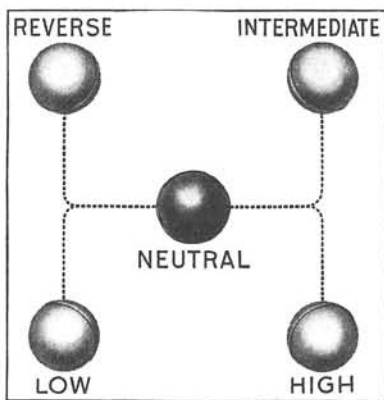

Figure 3  
Gear Shift Lever Positions

the rod, at the same time pressing down on the starter button with your foot. The instant the engine starts, withdraw your foot from the starter button and release the choke rod, next advance the spark lever about half way down the quadrant. When the engine warms up, turn the adjusting rod back to the right. Never drive continuously with adjusting rod more than  $\frac{1}{4}$  turn open. (See Adjustment of Carburetor, Page 24.)

When starting a warm engine, do not pull back the choke unless the engine fails to start on the normal mixture as there is a possibility of flooding the engine with an over rich mixture of gas. If you should by accident flood the engine, open the throttle and with the choke rod in normal position, turn the engine over a few times to exhaust the rich gas.

### Starting the Car

Release emergency brake lever. With the engine running, disengage the clutch by pushing down the left foot pedal. Move the gear shift lever to the left and back which is the low speed position (see Fig. 3). Gradually release pressure on the clutch pedal, allowing it to return to its normal position and at the same time increase the speed of the engine by pressing lightly on the accelerator.

Second Speed: When the car has reached a speed of five to eight miles per hour, engage second or intermediate speed as follows: Release pressure on accelerator and again disengage the clutch, moving the gear shift lever through neutral to the

### Starting the Engine

1. Release the lock cylinder by turning the switch key to the right as described on Page 6.

2. See that the spark lever is retarded; the throttle lever advanced three or four notches on the quadrant and the gear shift lever in neutral position.

3. If the engine is cold, turn the carburetor adjusting rod one full turn to the left to give it a richer mixture for starting. This rod serves both as a choke for starting and as an enriching adjustment. Next pull back



right and forward, second speed position. Allow the clutch pedal to gradually return to its normal position, and increase the speed of the car until it is running 12 to 15 miles per hour.

High Speed: Disengage the clutch as before, at the same time release the pressure on the accelerator and pull the gear shift lever straight back from second speed. Then engage the clutch and increase the speed of the engine as driving conditions may require.

### ***Shifting Back Into Low Speed***

When shifting from high to second speed, at car speeds not exceeding 15 miles per hour, there should be no hesitation in neutral; after disengaging the clutch the lever should be moved as quickly as possible, from high to second speed. Should it be necessary to shift from high to second at higher car speeds, it can be done by the following method:

Disengage the clutch and shift into neutral. Reengage the clutch and at the same time accelerate the engine; then disengage the clutch again and shift to second, after which reengage the clutch. With a little experience, this shift can be made quietly.

### ***Descending a Hill***

When descending long grades, have the transmission in gear, the clutch engaged and the ignition switch on. This allows the engine to turn over against compression and act as a brake.

On steep grades the car should be in second speed gear before descent is started. On exceptionally steep grades the low speed should be used. This increases the braking action of the engine.

Always leave the ignition switch on when descending an incline. Shutting off the switch allows raw gas to be drawn into the cylinders which washes the lubrication off the cylinder walls. Also unexploded gas collects in the muffler and when the switch is again turned on there is a possibility of blowing out the muffler.

### ***To Stop the Car***

Disengage the clutch by pushing forward on the left pedal and apply the foot brake by pressing forward on the right pedal. Except when a quick stop is necessary, it is advisable to apply the brake gradually. When driving on wet or slippery pavement, the speed of the car should be reduced by applying the foot brake before releasing the clutch. This method of braking prolongs the life of the brake lining, and is a safety factor.

In bringing the car to a final stop, keep the clutch disengaged until the gear shift lever has been moved into neutral position. To stop the engine, push in on the electro-lock cylinder until it snaps into the lock position.

### ***To Reverse the Car***

The car must be brought to a stop before attempting to reverse its direction. To shift into reverse, proceed as in shifting into low speed, except that the gear shift lever is moved to the left and forward.

### ***The Spark Control***

For average driving the spark lever should be carried about half way down the quadrant. Only for high speeds should the spark lever be advanced all the way down the quadrant. When the engine is under a heavy load as in climbing steep hills, driving through heavy sand, etc., the spark lever should be retarded sufficiently to prevent a spark knock.

### ***Driving the Car***

The different speeds required to meet road conditions are obtained by varying the pressure on the accelerator. Practically all the running speeds needed for ordinary travel are obtained in high gear; the low and second gear are used principally to give the car momentum in starting, and when the engine is subjected to a heavy load.

### ***The Owner's Responsibility in Caring for the Car***

A new machine requires more careful attention during the first few days it is being driven than after the parts have been thoroughly "worked in." To obtain best results, a new car should not be driven faster than 30 to 35 miles per hour for the first 500 miles. The oil in the engine should be changed as described on page 13 under Draining the Oil Pan. Never start out with your car until you are sure it has plenty of oil, water and gasoline.

See that an air pressure of 35 pounds is maintained in all tires. Under inflation causes more tire expense than anything else.

Inspect your battery every two weeks and keep it filled to the proper level with distilled water. If the water is allowed to evaporate below the top of the plates the life of the battery will be seriously affected.

Let the Ford dealer go over your car once a month, making any mechanical adjustments necessary to keep your car in proper running order.

### ***Do Not Rest Foot on Clutch Pedal***

Do not make a practice of resting your foot on the clutch pedal while driving, as this may cause the clutch to slip and unnecessarily wear the facing on the discs.

### ***Clutch Pedal Clearance***

The correct clearance or play for the clutch pedal is approximately 1". That is when the clutch pedal is depressed there should be about 1" movement in the pedal before it starts to disengage the clutch.

As the clutch facings wear this clearance or movement gradually grows less. Consequently it should occasionally be checked. Under no circumstances should the car be driven without clearance or play in the clutch pedal.

### ***Adjusting Clutch Pedal Clearance***

The adjustment is easily made by removing the clevis pin (see Fig. 4) and turning the release arm rod. Screwing the rod in decreases the clutch pedal play. Screwing the rod out increases the play. After making adjustment, be sure to replace clevis pin and cotter key.

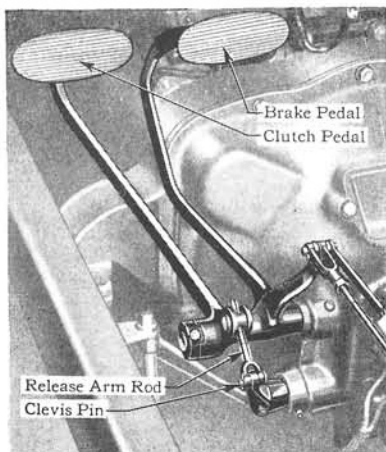

Figure 4  
Clutch Pedal Adjustment

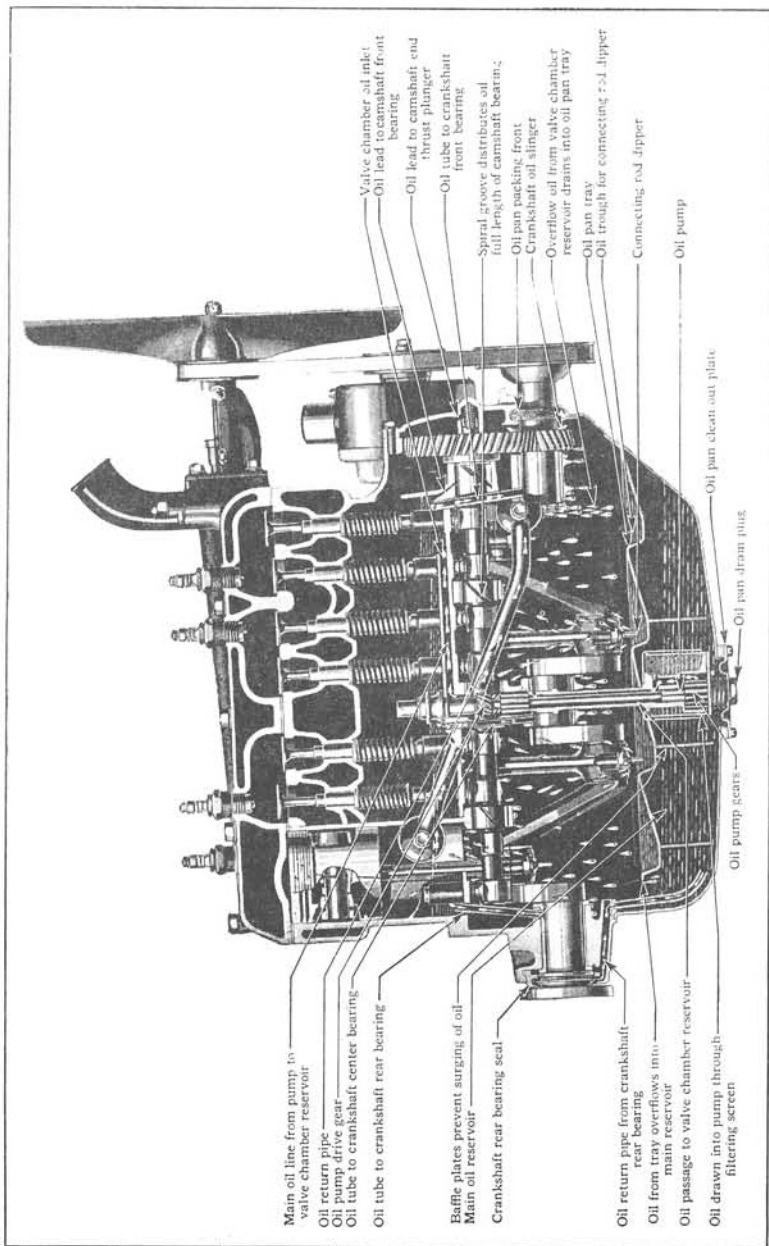

Figure 5  
Sectional View of Engine Showing Lubricating System

## THE FORD LUBRICATING SYSTEM

The purpose of lubrication is to reduce friction between moving surfaces. The oiling chart shown on pages 26-27 gives full information for lubricating the Ford car. Proper lubricating has a vital effect on the life of your car; consequently you should follow these instructions very carefully.

### *Engine Lubrication*

All parts of the engine are lubricated from the oil reservoir in the oil pan by the Ford Pump, Splash and Gravity Feed.

Only high grade engine oil should be used in the engine. Oil of this kind reaches the bearing surfaces with greater ease and cuts down frictional heat. It should have sufficient body so that the pressure between the two bearing surfaces will not force out the oil and allow the metal to come in actual contact.

Inferior oils have a tendency to carbonize quickly, also "gum up" the piston rings, valve stems and bearings. In cold weather a light grade of oil having a low cold test is absolutely essential for the proper lubrication of the car.

### *Draining the Oil Pan*

It is advisable to clean out the oil pan by draining off the old oil when the new car has been driven five hundred miles, and thereafter to repeat this operation every 500 miles. The oil should be warm before draining.

### *Lubricating the Differential*

Every 5000 miles the lubricant in the differential should be drained and the housing flushed with kerosene. New lubricant should then be added until it reaches the level of the oil filler hole in the housing.

### *Lubricating the Transmission*

About once every five thousand miles the gear lubricant should be drained from the transmission by removing the drain plug at bottom of transmission case. The interior of the transmission case should then be thoroughly flushed with kerosene and refilled with fresh gear lubricant.

The new lubricant is poured into the transmission through the filler hole, located at the right hand side of the transmission case. Pour sufficient lubricant in until it reaches the level of the filler hole.

### *Lubrication of the Clutch Bearing*

The clutch pilot bearing at the front end of the clutch is thoroughly packed with grease when the car is assembled, and it will not be necessary to lubricate this bearing until such time as the clutch may be disassembled. When the clutch is disassembled the bearing should be repacked with a good grade of cup grease.

Approximately every 2000 miles, lubricate the clutch release bearing. This is done by removing the hand hole cover and turning the bearing until the lubricator fitting is at the top. Lubricate the bearing by means of the compressor grease gun.

**NOTE:** The clutch is a dry disc clutch and under no circumstances should it be oiled.

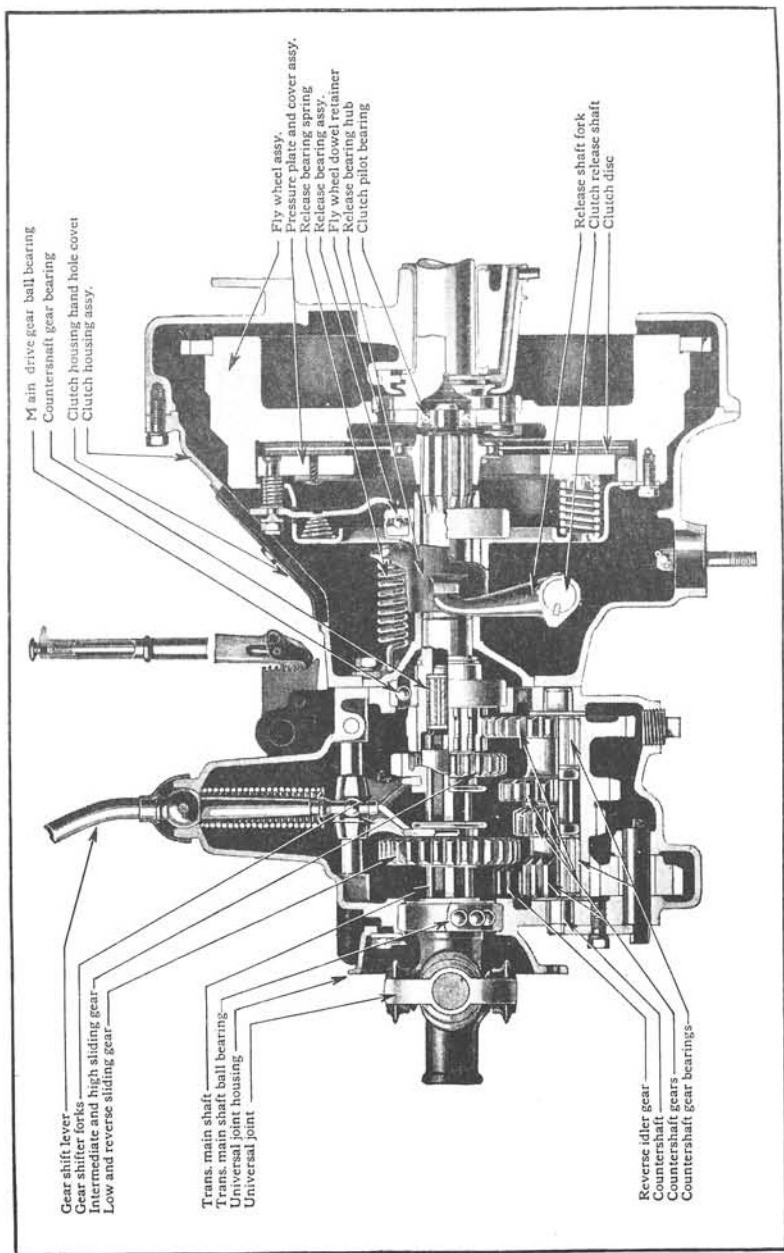

Figure 6  
Transmission and Clutch

### Greasing the Car

In order to properly force lubricant to all parts equipped with the conical shaped fittings, a high pressure compressor gun is employed. With this gun the lubricant can be forced in under a pressure of 2000 pounds or more per square inch, thus assuring a more thorough and positive lubrication than can be accomplished any other way.

A compressor gun is supplied with the tool equipment of each car, and by means of this device, lubricant can be forced into all bearings provided with conical shaped fittings.

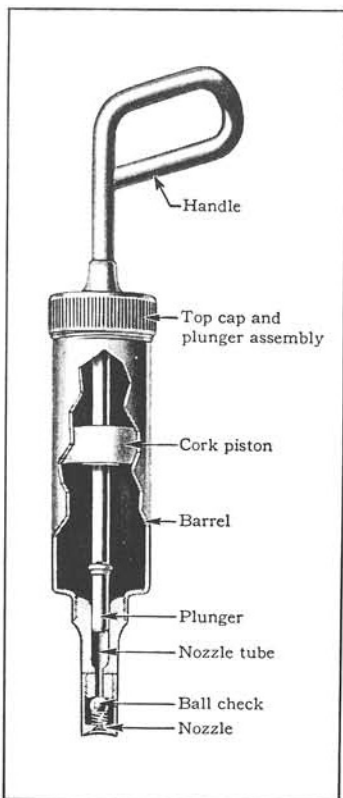

Figure 7  
Compressor Lubricating Gun

### Filling the Compressor

Remove top cap and plunger assembly (see Fig. 7). Fill the barrel with lubricant. Pack the lubricant solidly. To avoid air pockets, tap the nozzle gently on a board or work bench while filling. To prevent lubricant backing up and soiling hands, **FILL UP ONLY TO THE TOP OF THE LETTERING ON THE OUTSIDE OF THE BARREL.**

### Operating the Compressor

When the compressor is pressed against the conical shaped fittings, the plunger moves forward, forcing the lubricant in the nozzle directly through the fitting into the bearing, under an extremely high pressure.

When the pressure on the handle is released, grasp the barrel of the compressor with one hand and draw back the handle with the other, so as to load the compressor and make it ready to deliver a charge of lubricant with the next forward thrust.



### ***Oiling Generator and Starter Motor***

The bearings in the generator and starting motor are lubricated when they are installed in the car and require no further attention.

### ***Oiling the Distributor***

The distributor should be kept clean and well oiled. Put oil in the oil cup at the side of the distributor every 500 miles. Add sufficient oil to reach the level of the oil cup. Every 2000 miles remove the distributor cap, clean the lobes of the cam and apply a light film of vaseline.

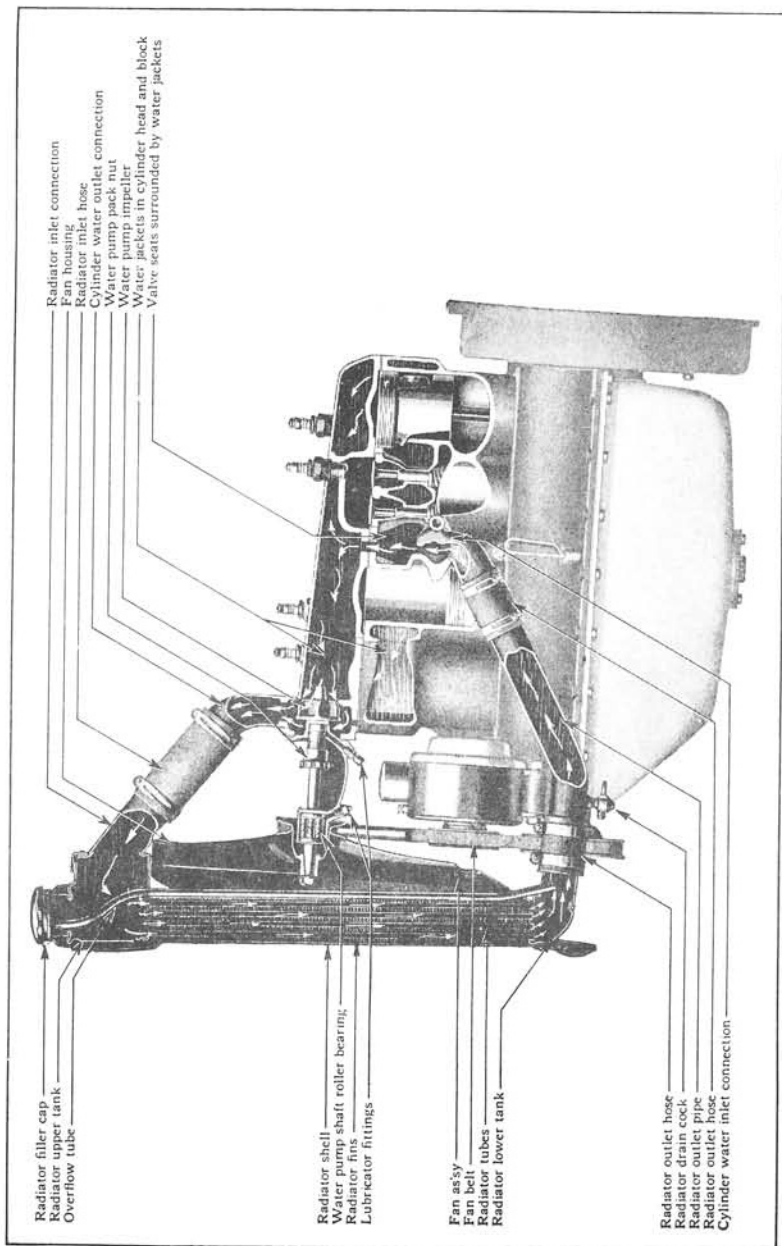

Radiator filler cap  
 Radiator upper tank  
 Overflow tube  
 Radiator inlet connection  
 Fan housing  
 Radiator inlet hose  
 Cylinder water outlet connection  
 Water pump pack nut  
 Water pump impeller  
 Water pump drive shaft  
 Valve seats surrounded by water jackets

Radiator shell  
 Water pump shaft roller bearing;  
 Radiator fins  
 Lubricator fittings

Fan ass'y  
 Fan belt  
 Radiator tubes  
 Radiator lower tank

Radiator outlet hose  
 Radiator drain cock  
 Radiator outlet pipe  
 Radiator outlet hose  
 Cylinder water inlet connection

Figure 8  
Cooling System

## THE FORD COOLING SYSTEM

### *Cooling the Engine*

The Ford engine is cooled by a circulation of water through the water jackets which surround the cylinders, combustion chamber and valve seats. The water is circulated by thermosyphon action, the flow of water being accelerated by means of a centrifugal water pump located in the front of the cylinder head. This pump draws the heated water from the engine into the upper radiator tank where it is cooled by filtering through the radiator tubes to the lower tank. The radiator is cooled by means of the fan located just back of the radiator where it draws a current of air around the radiator tubes.

To prevent overheating keep the radiator well filled. The capacity of the cooling system is three gallons.

### *Adjusting the Fan Belt*

The fan and water pump both operate from the same shaft. The shaft is driven by a "V" shaped rubber belt. The belt is adjusted to the proper tension when the car leaves the factory and this adjustment should not be changed unless the belt slips. The adjustment is easily made by loosening the generator support to engine screw and moving the generator toward you. Do not tighten the belt more than is actually necessary to keep it from slipping.

### *Water Pump Packing Nut*

Packing is used in forming a water tight connection around the water pump shaft. Should a leak develop, lubricate water pump shaft through water pump lubricator fitting, then tighten the packing nut. A screw driver is used for this purpose as shown in Fig. 9. Do not tighten the nut more than is necessary to stop the leak.

### *Cleaning the Radiator*

The entire circulating system should occasionally be flushed out. To do this open the petcock at the bottom of the radiator

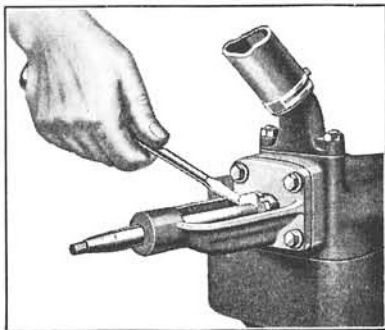
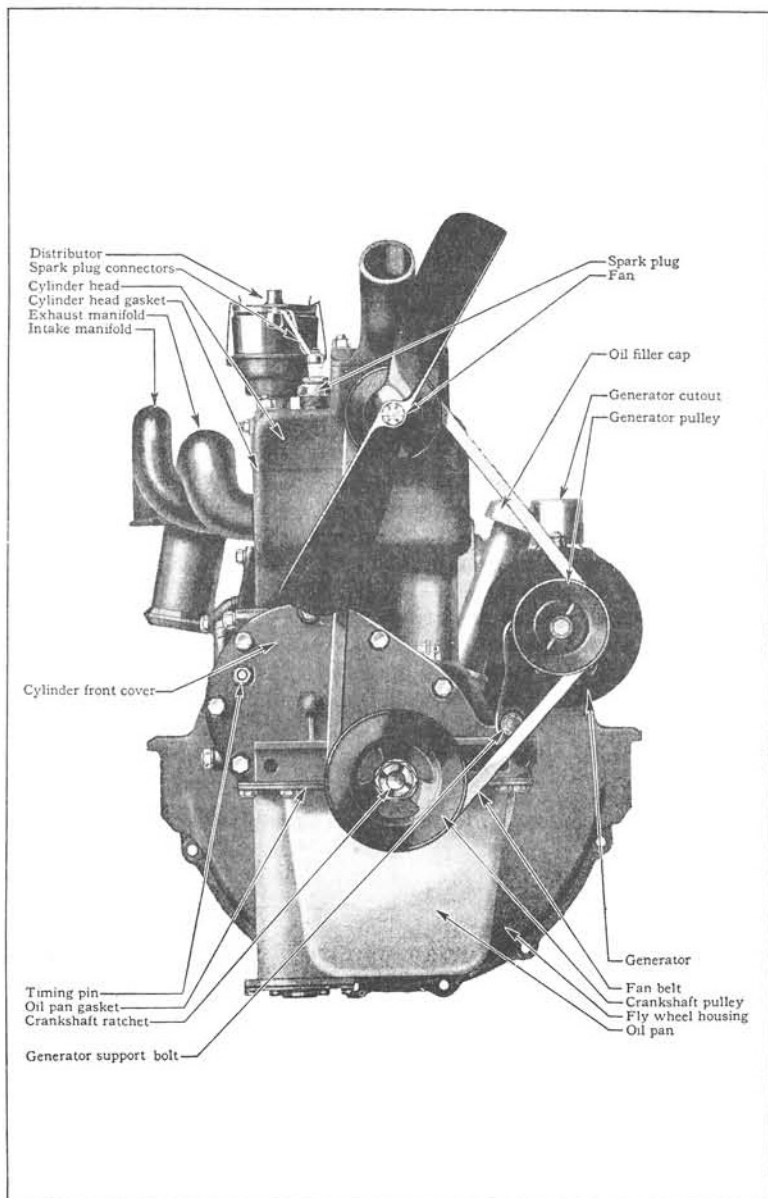

Figure 9  
Tightening Water Pump Shaft  
Packing Nut



**Figure 10**  
**Front View of Engine**

outlet connection pipe and insert a hose into the filler neck, allowing the water to flow through the system for about fifteen minutes or until the water comes out clear.

### ***Care of the Radiator in Winter***

In freezing weather it is necessary to use an anti-freeze solution in the circulating system to prevent freezing of the water, and bursting the tubes in the radiator.

Do not overlook the fact that constant evaporation will eventually weaken most anti-freeze solutions, consequently they should be tested frequently, especially in severe weather.

A suitable anti-freeze solution can be obtained from any authorized Ford dealer. Also complete directions as to the percentage of solution to be used to withstand the varying degrees of cold.

As anti-freeze solutions usually contain alcohol, care should be used when filling the radiator not to spill any of the solution, as it may damage the pyroxylin finish. After filling the radiator, be sure the radiator cap is screwed down tight.

## FUEL SYSTEM

### *Gasoline Tank*

The gasoline is carried in a ten-gallon tank welded integral with the cowl of the car. From this tank the gasoline flows by gravity to the carburetor, where it is mixed with air and drawn into the cylinders by piston suction.

A sediment bulb located on the engine side of the dash, is provided for draining off water or sediment that may have accumulated in the tank. Occasionally draining the bulb prevents foreign material being drawn into the carburetor.

### *The Carburetor*

The quantity of gasoline entering into the carburetor is governed by the float. The volume of gas mixture entering the intake manifold is controlled by opening and closing the throttle, according to the speed desired by the driver. Since, with the exception of the needle valve and idle adjustment all of the carburetor adjustments are fixed, about the only thing that could affect the carburetor would be dirt or water getting into it. An occasional cleaning will insure uninterrupted service. To clean the carburetor, remove the filter screen and thoroughly clean the screen by washing it in gasoline. The screen is easily removed by backing out the filter plug (see Fig. 12). It is also a good plan to occasionally remove the drain plug at the bottom of the carburetor and drain the carburetor for a few seconds.

### *Regulating Gasoline Mixture*

For economical driving, reduce the quantity of gasoline in the mixture by turning the adjusting rod to the right as far as possible without affecting the operation of the engine. This is particularly true when taking long drives where conditions permit a fair rate of speed being maintained, and accounts for the excellent gasoline mileage obtained by good drivers.

Turning the carburetor adjustment too far to the left results in a "rich mixture." Such a mixture has too much gasoline and should be used for starting and warming up only. Running with too rich a mixture causes excessive carbon and overheating, likewise it wastes fuel.

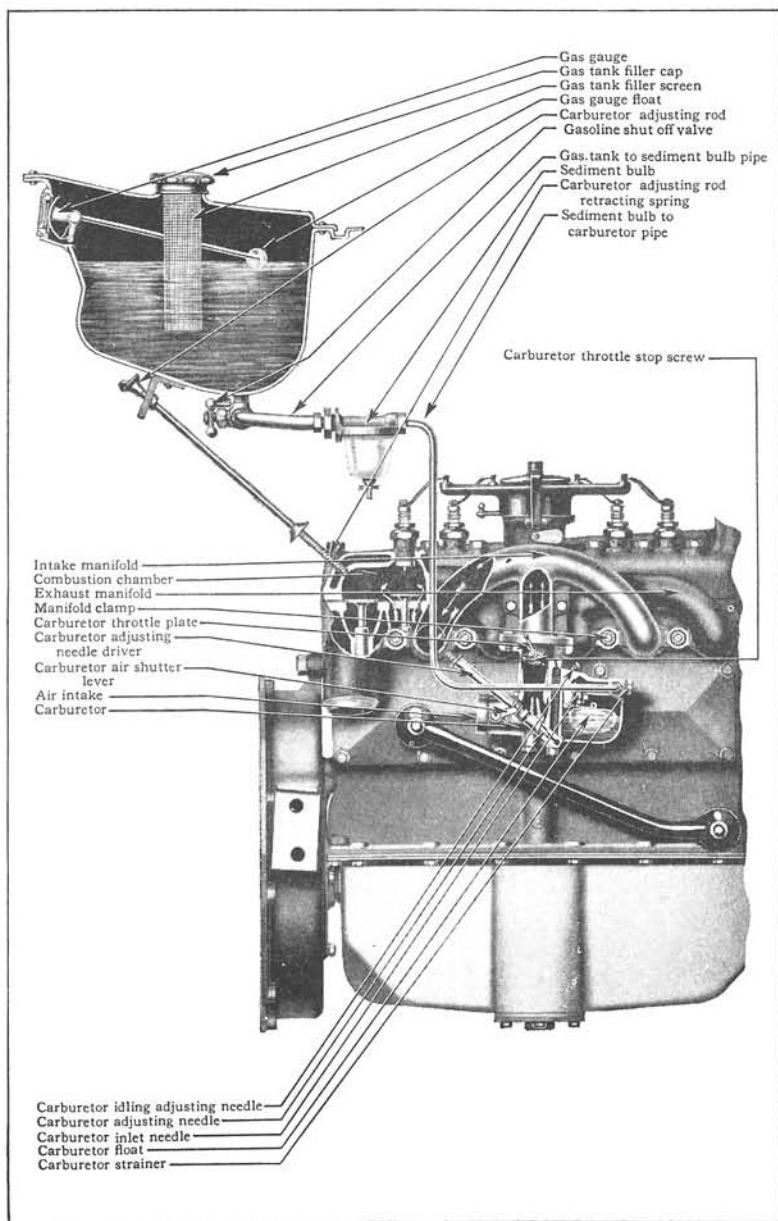

**Figure 11**  
**Fuel System**

### ***Adjustment of Carburetor***

The method of regulating the carburetor for ordinary driving conditions is to turn the carburetor adjusting rod to the right until the needle just seats, then turn the rod back approximately one-fourth of a turn.

### ***To Set Idle Adjustment Proceed as Follows:***

With engine warmed up, fully retard spark and throttle levers. Unhook throttle rod at carburetor. Adjust throttle adjusting screw so that the engine will run sufficiently fast to keep from stalling. Next turn idling adjusting screw in or out until engine runs evenly without rolling or skipping. Then slowly screw in throttle plate adjusting screw until engine picks up slight additional speed. Connect throttle rod to carburetor.

Do not expect an engine that is too stiff to "rock" on compression when stopped, to idle well at low speed.



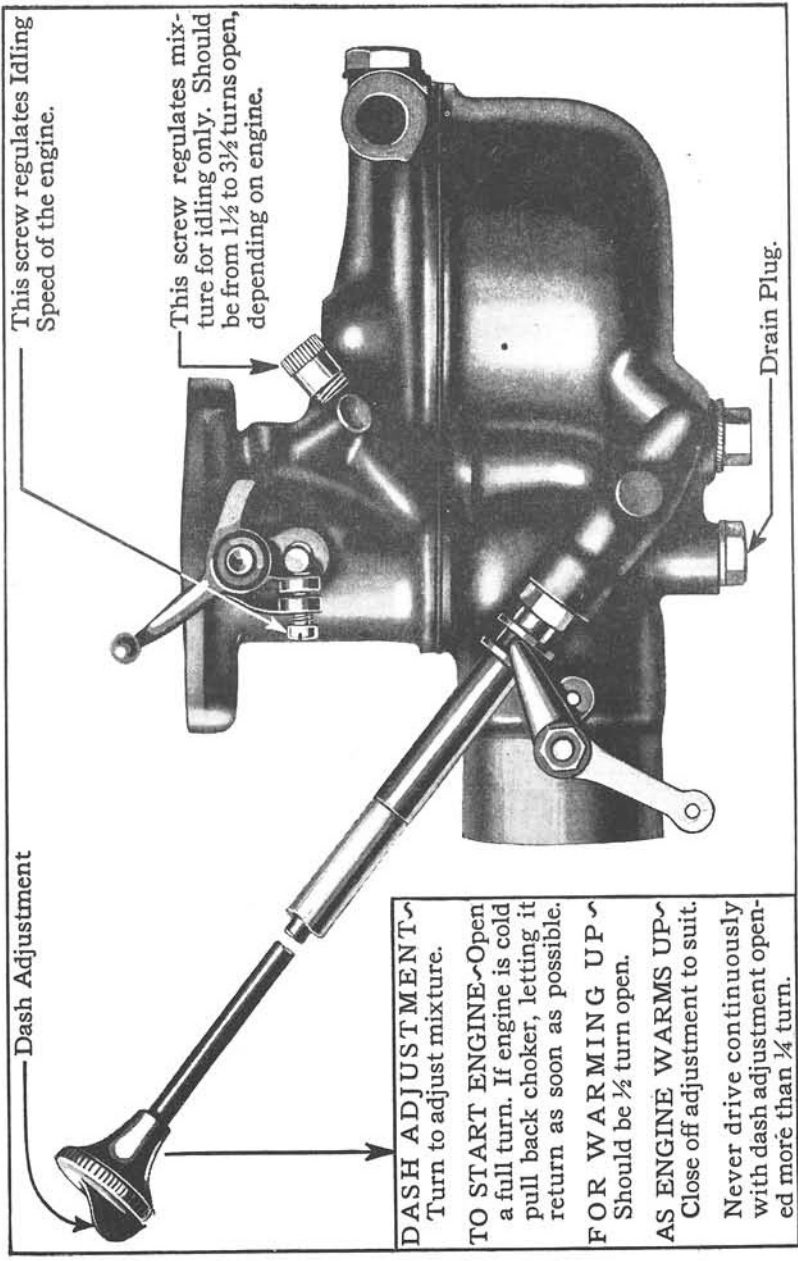

Dash Adjustment

This screw regulates Idling Speed of the engine.

This screw regulates mixture for idling only. Should be from 1 1/2 to 3 1/2 turns open, depending on engine.

Drain Plug.

**DASH ADJUSTMENT**  
Turn to adjust mixture.

**TO START ENGINE** Open a full turn. If engine is cold pull back choker, letting it return as soon as possible.

**FOR WARMING UP** Should be 1/2 turn open.

**AS ENGINE WARMS UP** Close off adjustment to suit.

Never drive continuously with dash adjustment opened more than 1/4 turn.

Figure 12

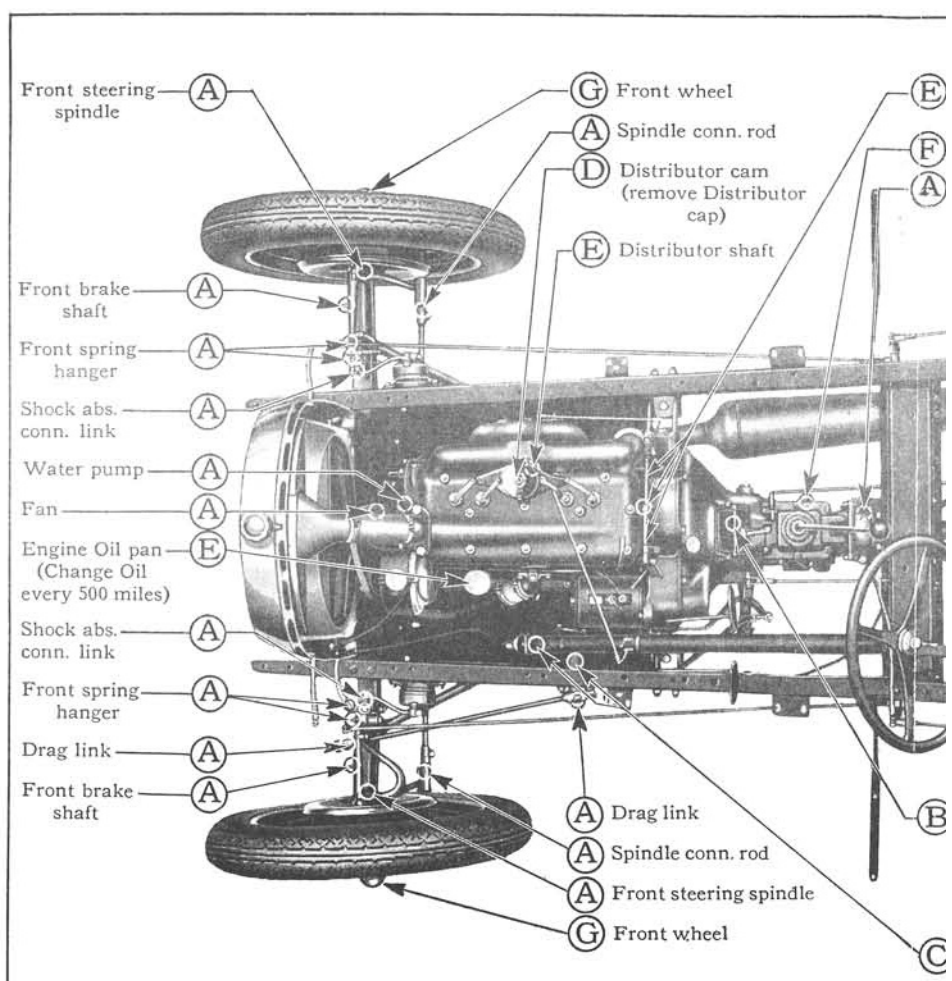

- (A) Grease every 500 miles (pressure gun)
- (B) Grease every 2000 miles (pressure gun)
- (C) Gear lubricant every 2000 miles
- (G) Pack with greas

Figure 13—Oil

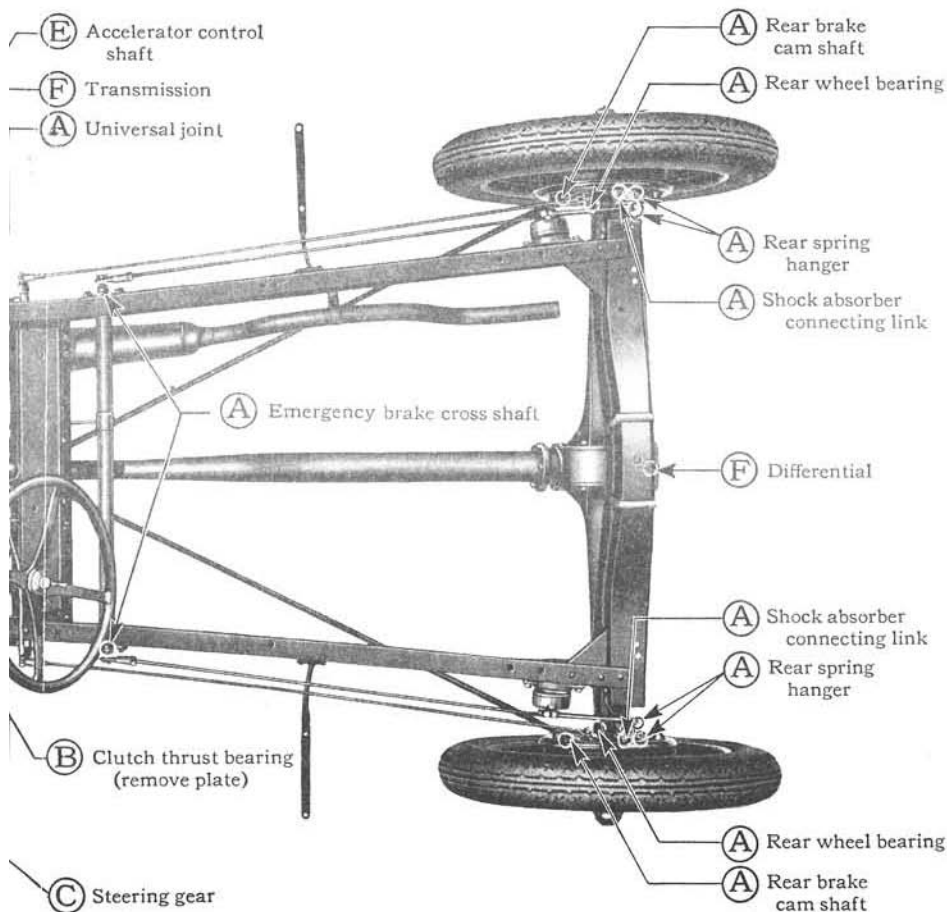

- 1) (D) Clean and apply light film of vaseline every 2000 miles  
 in) (E) Oil every 500 miles  
 (F) Gear lubricant every 5000 miles  
 grease— every 5000 miles

## ELECTRICAL SYSTEM

The electrical system includes the following equipment:

- Storage Battery
- Generator
- Starting Motor
- Distributor
- Ignition Coil
- Spark Plugs
- Ammeter
- Horn
- Lamps
- Windshield Wiper

### *Engine Ignition*

The current for igniting the gas mixture in the cylinders is provided by the storage battery. The ignition coil transforms the low tension current to a high tension current of sufficient voltage to jump between the points of the spark plugs. The distributor breaker points interrupt the flow of low tension current at regular intervals, while the distributor rotor distributes the high tension current to each spark plug in proper firing order.

### *Adjusting Breaker Contact Points*

The gap between the breaker points is set at .018 to .022". The gap should occasionally be checked to see that the points are properly adjusted.

If the points are burnt or pitted they should be dressed down with an oil stone. ***Do not use a file.***

To adjust the points proceed as follows:

Lift off distributor cap, rotor, and body.

Turn engine over slowly with starting crank until breaker arm rests on one of the four high points of the cam with the breaker points fully opened.

Loosen lock screw and turn the contact screw until the gap is between .018 and .022". A standard thickness gauge is used to obtain this measurement.

### *Ignition Timing*

As the spark must occur at the end of the compression stroke the timing must be checked from that point. To find the compression stroke and time the spark proceed as follows:

1. Fully retard spark lever.
2. Check gap between breaker contact points and if necessary adjust them as described on page 28.
3. Screw out timing pin located in timing gear cover (see Fig. 10) and insert opposite end of pin into opening.
4. With the starting crank turn the engine over slowly, at the same time pressing in firmly on the timing pin. When the piston reaches the end of the compression stroke the timing pin will slip into a small depression in the camshaft gear.
5. With the pin in place, remove the distributor cover and lift off rotor and distributor body.
6. Loosen cam locking screw until cam can be turned.
7. Replace rotor and turn it until the rotor arm is opposite No. 1 contact point in distributor head.
8. Withdraw rotor from cam and slightly turn the cam in a counter clockwise direction until the breaker points just start to open, then securely tighten cam locking screw.
9. Replace rotor and distributor cover.
10. **Withdraw timing pin from depression in time gear and screw it back tightly into the timing gear cover.**

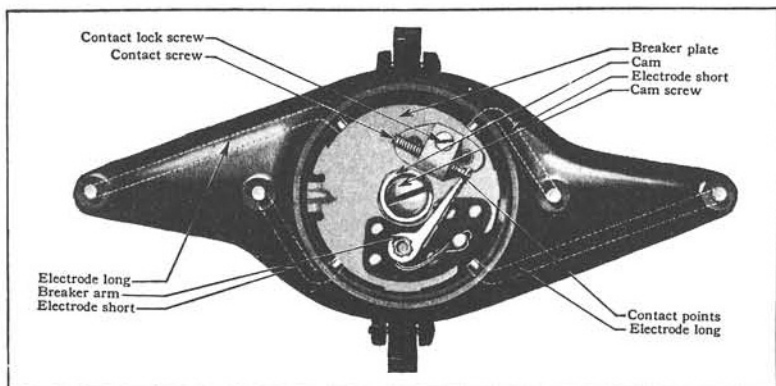

Figure 14  
Top View of Distributor

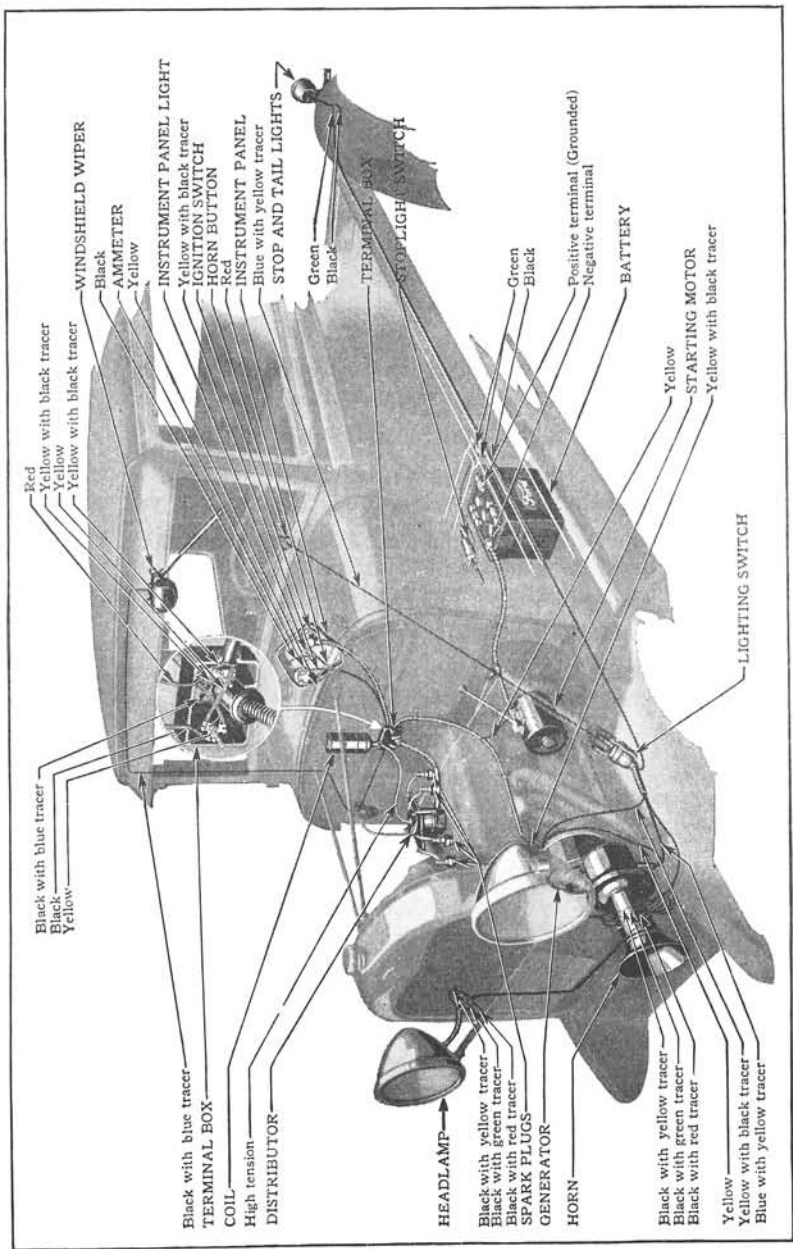

Figure 15  
Ignition System

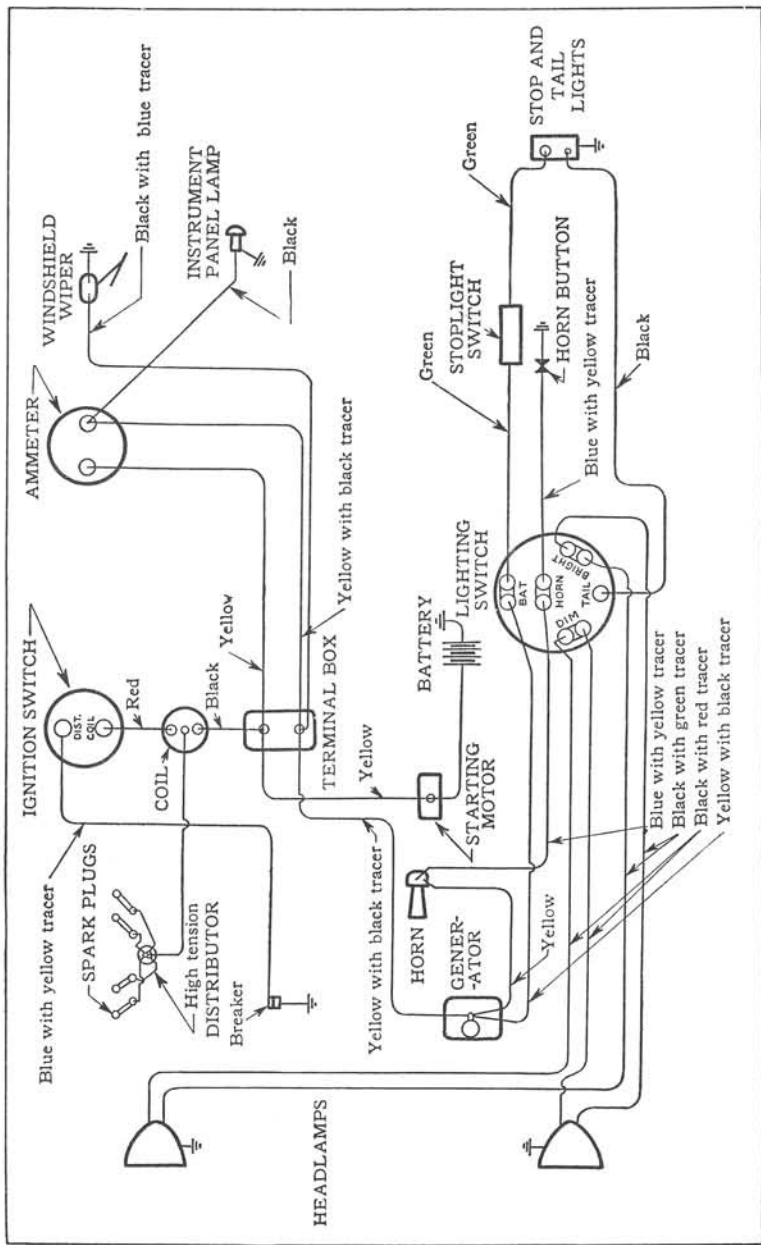

Figure 16  
Wiring System

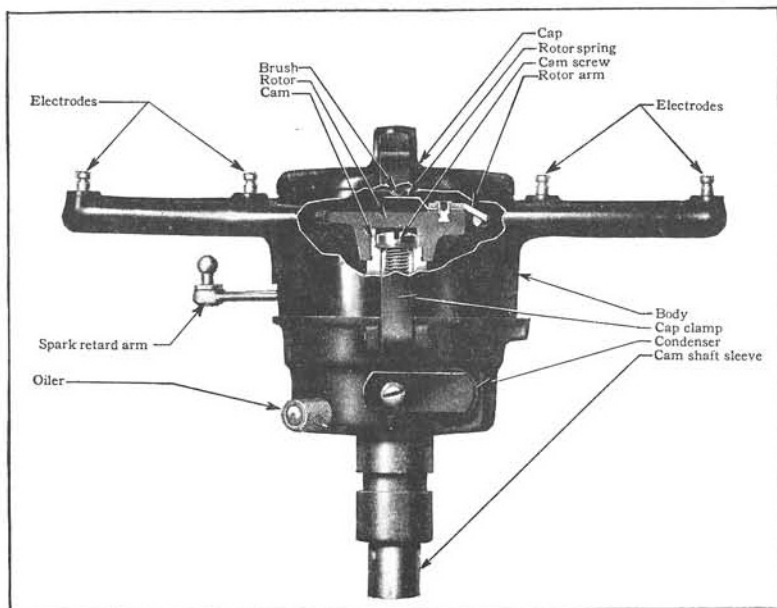

Figure 17  
Side View of Distributor

### *The Ford Battery*

The Ford Starting System uses a six-volt, 80 ampere hour, 13-plate battery, designed and built to meet the requirements of the Ford car.

### *Adding Water to Battery*

Every two weeks check the electrolyte in the battery to see that it is at the proper level. The solution (Electrolyte) should be maintained at a level with the bottom of the filling tube. If below this point, add distilled water until the electrolyte reaches the proper level. Water for battery use should be kept in clean, covered vessels of glass, china, rubber or lead. In cold weather add water only immediately before running the engine so that the charging will mix the water and electrolyte and prevent freezing. Access to the battery is easily made by removing a small plate located in the floor board in front of the driver's seat. To remove the battery from the car it will be necessary to take out the floor boards. **When replacing the battery in the car be sure to install it with the POSITIVE terminal grounded to the frame as shown in Fig. 15.**



### ***Care to Be Given Filling Plugs and Connections***

Keep the battery filling plugs and connections tight, and the top of the battery clean. Wiping the battery with a rag moistened with ammonia will counteract the effect of any of the solution which may be on the outside of the battery. A coating of vaseline will protect the terminals from corrosion. It is of vital importance that the battery is firmly secured in its supporting brackets at all times. If clamps are loose, the battery will shift about in the compartment resulting in loose connections, broken cells and other trouble. When repairs are necessary, or if the car is to be laid up for the winter, take the battery to a Ford dealer for proper attention and storage. Do not entrust your battery to inexperienced or unskilled hands.

### ***The Generator***

The generator is mounted on the left hand side of the engine. During winter months in sections where low temperatures prevail, the charging rate should be adjusted to 10 amperes; in the summer this rate should be cut down to 6 amperes. The rate can, of course, be increased or decreased to meet individual requirements. For example, the owner who takes long daylight trips could cut the charging rate down even less. On the other hand, the owner who makes numerous stops, should increase the normal rate if his battery runs down.

### ***Increasing or Decreasing Generator Charging Rate***

To increase or decrease the generator charging rate, remove generator cover and loosen field brush holder lock screw. The field brush holder can be easily identified as it is the only one of the brush holders that operates in a slot in the brush holder ring and which is provided with a locking screw. The remainder of the brush holders are riveted to the ring and are not movable. To increase the charging rate shift the field brush holder in the direction of rotation, to reduce the rate shift the brush in the opposite direction. The output of the generator is indicated by the ammeter located on the instrument panel.

### ***The Starting Motor***

The starting motor is mounted on the left side of the engine. It requires no attention beyond seeing that the cable connection is clean and tight.

### ***The Ignition Coil***

The ignition coil mounted on the dash receives the low tension current from the battery, and transforms it into the high tension current necessary to produce the spark at spark plug. Occasionally inspect the wire connections at the coil, distributor and spark plugs to see that they are clean and tight.

### ***The Spark Plugs***

The spark plugs are the medium through which the electric current ignites the gasoline charge in the cylinder. Hard starting or misfiring of the engine may be caused by dirty spark plugs or incorrect spark plug gap. Keep the plugs clean and the gap set to .027.

There is nothing to be gained by experimenting with different makes of spark plugs. The spark plugs with which Ford engines are equipped when they leave the factory are best adapted to the requirements of the Ford engine.

### ***The Ammeter***

The ammeter is located on the instrument panel. It registers "charge" when the generator is charging the battery, and "discharge" when the lights are burning and the engine running about 10 miles per hour or less. If the engine is running above 15 miles per hour and the ammeter does not register "charge," with the lights off, consult a Ford dealer.

### ***Operation of the Lights***

The lighting system is operated by a switch handle located at the top of the steering wheel. When the lighting switch handle is pointed straight down, the lights are off. Turning handle first position to right from the "off" position gives a downward tilting beam for city driving. Turning handle to second position to right provides a beam which gives exceptionally brilliant road illumination for country driving. Turning handle all the way to the left turns on the parking lights.

### ***Replacing the Bulbs***

When replacing burned out bulbs, make certain that you get genuine Ford bulbs, as satisfactory results cannot be obtained with the many inferior bulbs now on the market. Genuine Ford bulbs have the name FORD marked on the base. They insure your headlights meeting the lighting requirements of the various States.

### ***Headlamp Requirements***

When the car is delivered, the headlamps are properly focused and aligned, and will pass the lighting requirements of all states.

Should the lamps get out of focus or alignment they should immediately be refocused and realigned. Ford dealers are equipped to do this work, or if you have the proper facilities you can make the adjustment.

### ***Focusing and Aligning Headlamps***

Align and focus headlamps with empty car standing on a level surface in front of a white wall or screen 25 feet from front of headlamps. This wall must be in semi-darkness or sufficiently shielded from direct light so that the light spots from the headlamps can be clearly seen. The wall must be marked off with black lines as shown in Figs. 18 and 19. Details for making the layout are shown in Fig. 20.

### ***Focus***

1. Lens must be installed in door with the word "top" at top of door and with all lettering reading properly from front.
2. Turn on upper beam.
3. Focus by means of screw at back of lamps, first one lamp and then the other, adjusting the bulb filament at the focal center of the reflector to obtain an elongated elliptical spot of light on the wall, with its long axis horizontal (see Fig. 12). In focusing, adjust the bulb to obtain as good contrast and well-defined cut-off across the top of the spot of light as possible.

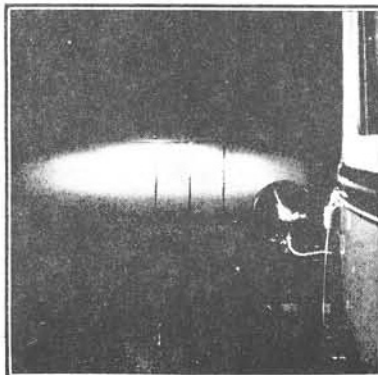

**Figure 18**  
**Left Headlamp Properly**  
**Focused and Aligned.**

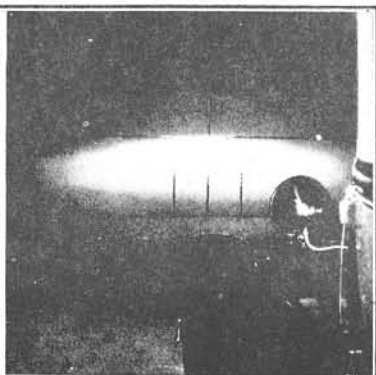

**Figure 19**  
**Both Headlamps Properly**  
**Focused and Aligned.**

With lamps thus focused for the upper beam the lower beam will be in satisfactory position.

No adjustment is necessary for small bulb for parking light.

### Alignment

1. Headlamps are aligned by moving lamps after nut at bottom of bracket has been slightly loosened.

2. The tops of the bright spots on the 25-foot wall are to be set at a line 37 inches above level of surface on which car stands. (See Fig. 20.) With tops of bright spots thus set for empty car, the headlamps comply, under all conditions of loading, with the requirements of the various states.

3. The beam of light from each headlamp is to extend straight forward; that is, the centers of the elliptical spots of light must be 30 inches apart.

Proper alignment of headlamps is readily checked by means of a horizontal line on the wall in front of the car, 37 inches above the level surface on which car stands, and two vertical lines 30 inches apart, each one 15 inches from center line of car. Proper alignment of car relative to marks on the wall may be readily provided by use of wheel guide blocks for one side of the car, as shown in cut. If it is impossible to tie up the floor space required by these blocks, marks painted on the floor may be used to show where one set of wheels should track and where the car should be stopped.

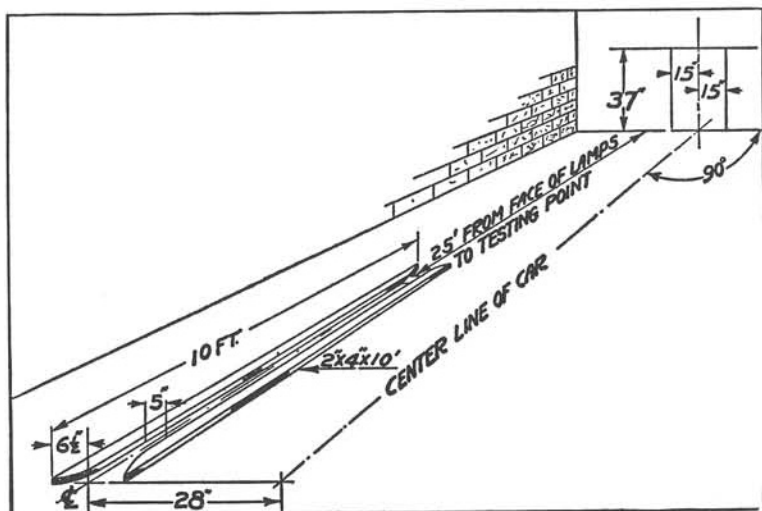

Figure 20

Shop Layout for Focusing and Adjusting Headlamps.

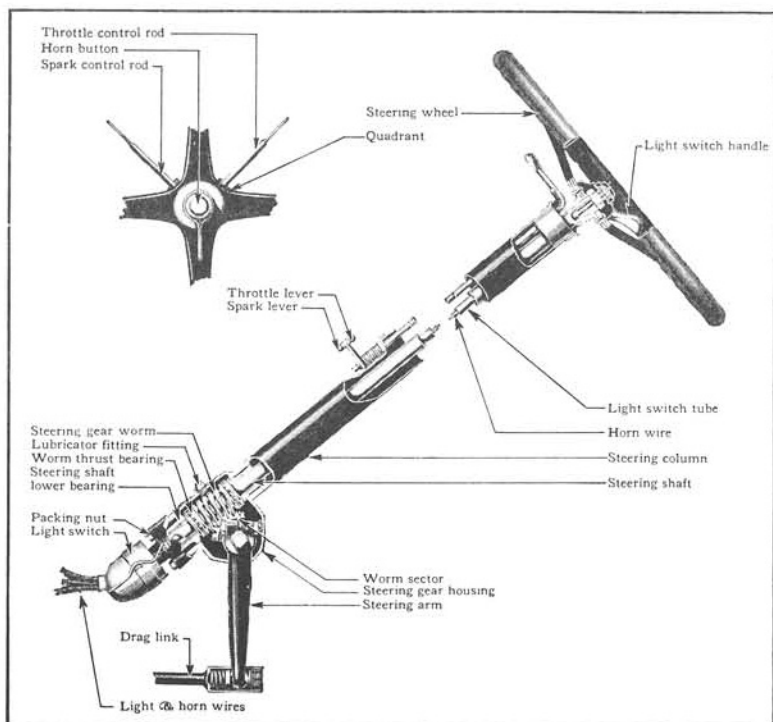

Figure 21  
Steering Gear Assembly

## THE RUNNING GEAR

### *Care of Running Gear*

Every few weeks the front and rear axles should be carefully gone over to see that all nuts and connections are tight, with cotter pins in place. The spring clips should be inspected occasionally to see that they are tight.

### *The Front Wheels*

The front wheels should be jacked up periodically and tested for smoothness of running and excessive side play. To determine if there is excessive side play, grasp the sides of the tire and shake the wheel. Do not mistake loose spindle bushings for loose bearings. Insert a cold chisel between spindle and axle when making this test to take up any spindle bushing play.

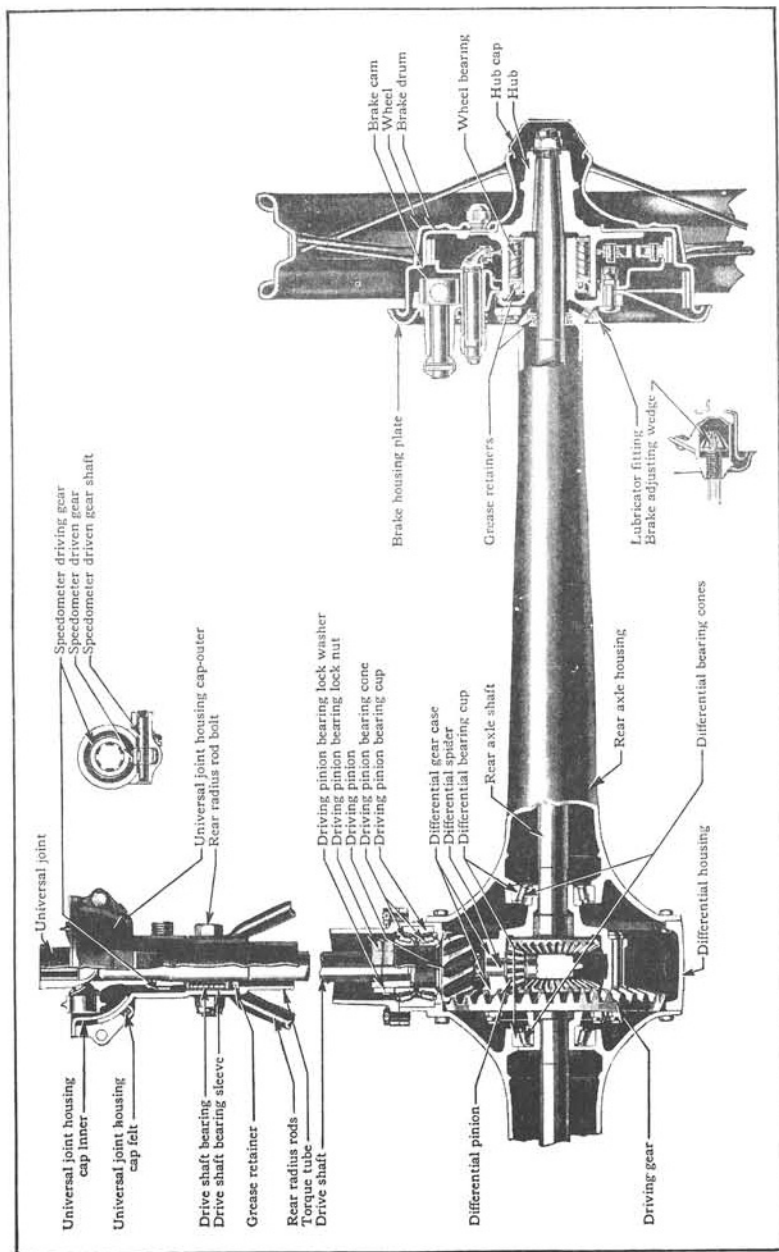

Figure 22  
Rear Axle Assembly

### ***Adjusting Front Wheel Bearing***

If there is excessive play in the bearing it can be adjusted as follows: Remove wheel. Withdraw cotter key and tighten adjusting nut until the hub just starts to bind. Then back off the adjusting nut one or two notches until the hub can be freely revolved. Before replacing the wheel, ***be sure to insert cotter key in adjusting nut.***

### ***Care of Springs***

The springs should be lubricated occasionally with oil or graphite. This will restore the original flexibility of the springs and improve the riding quality of the car.

## STEEL SPOKE WHEELS AND TIRES

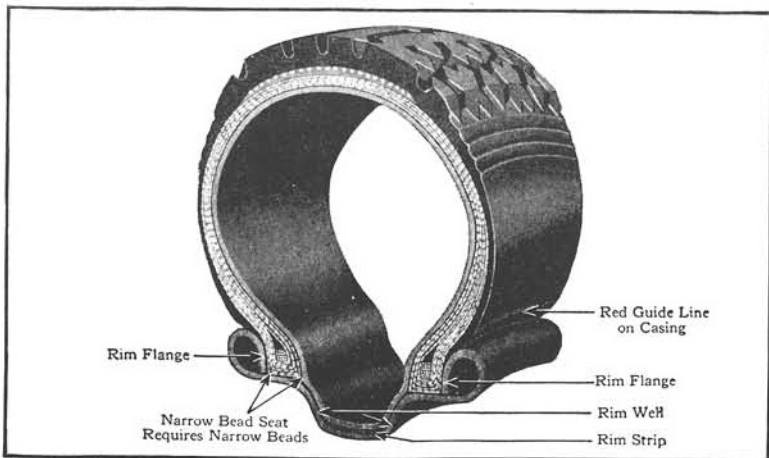

Figure 23  
Sectional View of Tire and Rim

### ***Ford Steel Spoke Wheels***

To remove Ford steel spoke wheels, jack up the side of the car from which the wheel is to be withdrawn and screw off the five hub bolt nuts. The wheel can then be removed. When replacing a wheel, tighten each hub bolt nut a few turns at a time. Then follow around hub, tightening each nut firmly. If nuts are not drawn up evenly, the wheel will not run true.

### ***Removing Tires From Ford Steel Spoke Wheels (Drop Center Rims)***

Remove valve cap and lock nut and place wheel so that valve is at the top. Let all air out of tube. Push valve stem up into tire. Working both ways from the valve stem, press



Figure 24  
Mounting Tire on Rim

marked with a red dot on red guide line, the tube must be placed in the tire with the valve stem at point marked with the red dot. (Caution: never use a tire flap when mounting tires on Ford Steel spoke wheels.) With wheel placed so that valve stem hole is at top, place casing and tube on wheel with valve in valve stem hole. (See Figure 24.) Working both ways from the valve stem, press the casing together and down into the rim well, until lower part of casing can be forced over rim flange at bottom. A tire iron may be used if necessary. (See Figure 25.) Raise tire up, (see Figure 26) until it is perfectly centered on rim and beads are seated on bead seats. Inflate tube to not more than two pounds pressure and work casing back and forth to insure proper setting of tire, indicated by red line on tire being equally spaced from rim all way around. (See Fig. 27.) **CAUTION:** With Ford steel spoke wheels (drop center rims) use only casing with red centering line just above rim flange, and tubes marked "for drop center rims."

It is particularly important that the red line show an even distance from the rim all around on both sides be-

the tire together and down into the rim well, approximately one foot each side of the valve stem. Insert tire iron under both beads at point opposite valve and force tire over rim. The tire can then be removed from the wheel with the hands.

### *Mounting Tire on Ford Steel Spoke Wheels (Drop Center Rims)*

Inflate tube until it is barely rounded out, and insert tube in casing. If tires are

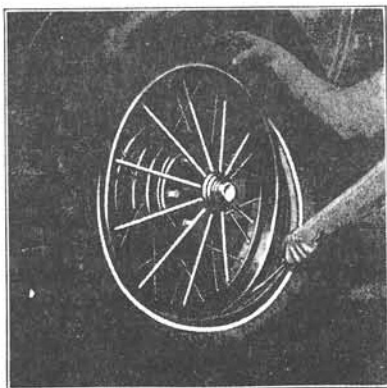

Figure 25  
Installing Tire



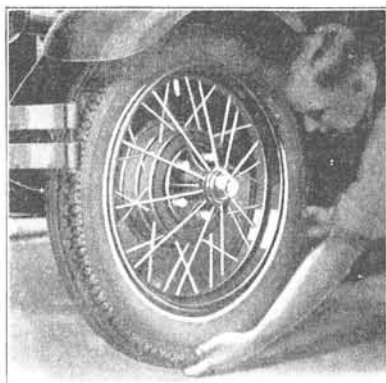

Figure 26  
Centering Tire on Rim

as rim cutting. *Keep both front and rear tires inflated to 35 lbs. and check the pressure once a week.*

Never run on a flat tire, even for a short distance. Skidding also shortens the life of the tires. Avoid locking the wheels with the brakes—no tire will stand the strain of being dragged over the pavement. Avoid running in street car tracks, or bumping the sides of the tire against the curbing.

To get most service at least expense, tires should be inspected frequently and all small cuts or holes properly sealed or repaired, thus preventing dirt and water working in between the rubber tread and the fabric, causing blisters or sand holes.

### **Care of Tires When Car is Stored**

When a car is idle for any appreciable length of time, it should be jacked up to take the load off the tires. If the car is laid up for several months, it is best to remove the tires. Wrap up the outer casings and inner tubes separately, and store them in a dark room not exposed to extreme temperatures. Remove oil or grease from the tires with gasoline.

fore fully inflating tire. Put valve nut on valve, inflate tire to 35 pounds and screw valve cap down tightly. (See Figure 27.) With Ford steel spoke wheels, tires can be more easily changed with wheel mounted on axle or tire carrier then by laying the wheel on ground.

### **Keep Tires Inflated to 35 Pounds**

Tires should never be run partially inflated, as the side walls are unduly bent and the fabric is subjected to stresses which cause what is known

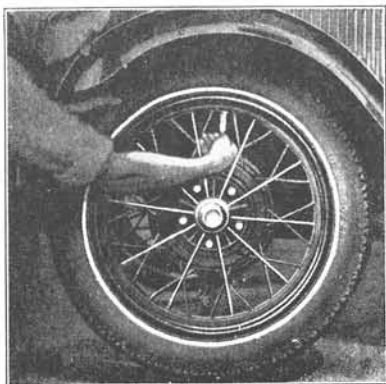
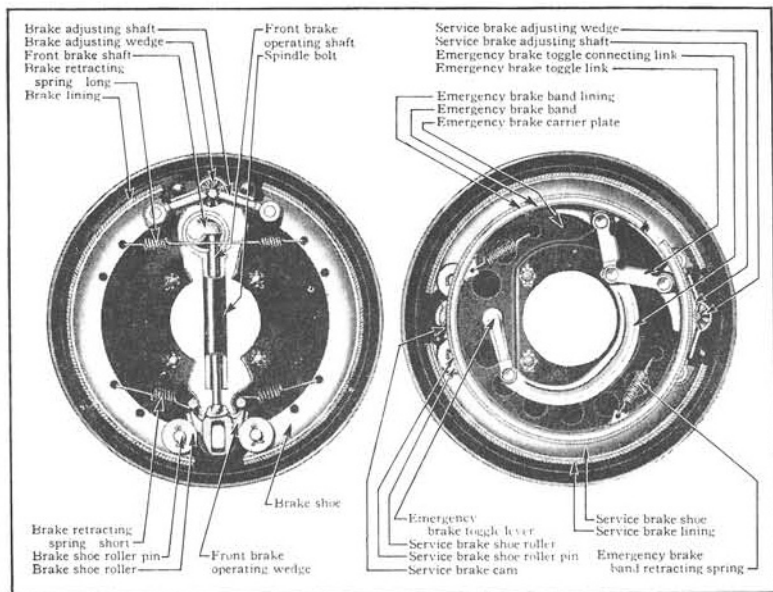

Figure 27  
Red line on tire must show even distance from rim all the way around the tire.



Front Brake

Figure 28

Rear Brake

## BRAKES

The braking system includes four internal expanding service brakes, one on each wheel, and an emergency or parking brake on each rear wheel which is also an expanding brake. This design is made possible by specially developed two in one brake drums on the rear wheels.

The four wheel service brakes are operated by the foot brake pedal. The emergency brakes are operated by the emergency brake lever and are entirely separate and distinct from the four wheel service brakes.

Both sets of brakes are of the mechanically operated design, of simple construction insuring positive action and highest efficiency at all times.

### *Adjusting Four Wheel Service Brakes*

Make all adjustments with brakes cold. Fully release emergency brake lever.

Raise rear end of car sufficiently to allow wheels to spin free from floor.

Turn adjusting wedge at both rear brakes until the brake drags then back off the wedge two or three notches or just enough to allow the wheels to revolve without drag.

To insure correct equalization, the same person should check the brake pressure by rotating the wheel.

After adjusting rear brakes, adjust the front brakes in the same manner.

If adjustments are correctly made the brakes should operate as follows:

1. Rear brakes should just start to hold when brake pedal is depressed approximately 1 inch.

2. Depressing pedal about  $\frac{1}{2}$  inch farther should tighten but not lock rear brakes and cause front brakes to just start to hold.

3. Depressing pedal approximately another  $\frac{1}{2}$  inch should lock rear wheels and hold the fronts very tightly. With properly adjusted brakes this should not exceed one-half of the total possible pedal movement.

4. When brake pedal is applied with full pressure, rear wheels should slide and fronts should make a heavy impression or road print, which condition is obtained just before sliding.

When all of the adjustment on the adjusting wedges is used up, it will be necessary to reline the brakes. When this becomes necessary we suggest you take your car to an authorized Ford dealer. They are provided with special relining equipment.

### ***Adjusting Emergency Brakes***

The emergency brake requires little attention from an adjustment or service standpoint, and with ordinary care will last indefinitely. Only when the band linings become excessively worn, permitting the emergency brake lever to come back to the extreme rearward position, will adjustment be required for wear. When this occurs adjustment can be easily made as follows:

1. Fully release emergency brake lever.

2. Remove rod that connects emergency brake lever to cross shaft center lever.

3. Next replace the rod inserting it through hole in center cross member and connecting the rod to the cross shaft center lever through UPPER hole in lever.

***Never adjust for wear by shortening the pull rods.***

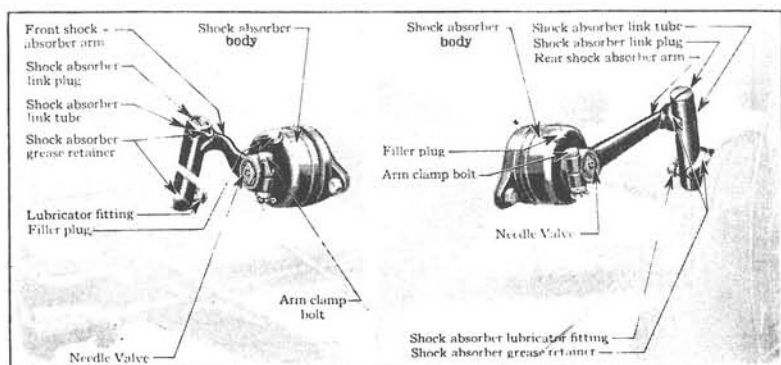

Figure 30

Front Shock AbsorberRear Shock Absorber

## SHOCK ABSORBERS

Ford hydraulic double acting shock absorbers operate entirely on the principle of hydraulic resistance. Glycerine is forced from one chamber to another by the movement of the lever arm. The working chamber is automatically kept full by the glycerine in the reservoir.

### *Adjustment:*

Turning the square end of the needle valve (see Fig. 30) changes the adjustment. Resistance is increased when the needle is screwed in, and decreased when the valve is backed out.

The average adjustment for rear shock absorbers during warm weather is made as follows: Screw needle valve in until it seats, then back valve off  $\frac{1}{4}$  turn. For front shock absorbers, back valve off  $\frac{3}{8}$  of a turn.

For cold weather adjustment the needle valve in the rear shock absorbers should be screwed in until it seats, then backed off  $\frac{1}{2}$  to  $\frac{5}{8}$  of a turn. For front shock absorbers the needle valve should be backed off  $\frac{5}{8}$  to  $\frac{3}{4}$  of a turn. A slight movement of the needle valve either way makes a big difference in the action of the instruments.

These settings are of course only approximate and can be easily changed to suit the individual preference of the owner and the conditions under which the car is operated. For example, the owner who drives at high speed over rough roads would

require greater shock absorber resistance than the owner who drives at moderate speed over paved highways.

### **Care**

The only care the shock absorbers require is replenishing the glycerine in the reservoir and the lubrication of the connections. The filler plug in the reservoir should be removed at intervals of 5,000 to 10,000 miles, and the reservoir filled with glycerine (Commercial). **NEVER REPLENISH WITH OIL.** Oil will solidify in the winter or reduce resistance and will not mix with the glycerine in the instruments.

In warm climates, replenish with glycerine, C. P. or Commercial. All instruments contain glycerine with 10% alcohol. Where temperatures of zero and below are prevalent, add an additional  $\frac{1}{2}$  to 1 ounce of alcohol.

### **Lubricating Shock Absorber Connections**

The ball joints are made in unit with the instrument arm and spring perches. They are hardened and ground. The ball joint seats are enclosed in the shock absorber connecting links, which should be lubricated every 500 miles with the compressor gun.

In order to secure maximum riding comfort, it is important that the spring hangers be free in the bushings and kept well greased.

## SPEEDOMETER

The speedometer with which your car is equipped indicates the speed and records the mileage of your car. It also helps you in maintaining an accurate lubrication schedule.

### **Resetting the Trip Odometer**

To reset the trip odometer simply pull out the knob on the speedometer. By turning the knob you can reset the figures at any tenth of a mile desired, or back to zero. After resetting the odometer be sure to push the knob back to its original position.

### **Lubrication**

The flexible shaft should be lubricated every 5,000 miles. Care should be exercised not to bend the shaft in a radius smaller than 7".

For maximum service we recommend that every 10,000 miles the speedometer be cleaned, lubricated and recalibrated. When this is necessary or when repairs are required consult an authorized Ford dealer.

All speedometers are sealed when they leave the factory. Under no circumstances should this seal be broken or repairs attempted by the owner.

## POINTS OF MAINTENANCE

### *The Proper Way to Wash the Car*

Always use cold or lukewarm water—never hot water. If a hose is used, don't turn the water on at full force as this drives the dirt into the finish. After the surplus mud and grime have been washed off, take a sponge and clean the body and running gear with a solution of water and linseed oil soap. Rinse off with cold water; then rub and polish the body with a damp chamois skin. A body polish of good quality may be used to add lustre to the car. Grease on the running gear may be removed with a gasoline soaked sponge or rag. The nickeled parts should be polished with a good nickel polish. An excellent body polish and nickel polish can be purchased from any Ford dealer.

Should the body or other pyroxylin finished parts of the car become spattered with tar or other substances used on roads, the spots can be removed with a solution of  $\frac{2}{3}$  gasoline and  $\frac{1}{3}$  engine oil.

Dip a soft cloth into the mixture and, using one finger, rub the spot gently until it has been removed. The rubbed spot should then be washed off with clear water.

### *Care of the Top*

When putting down the top be careful in folding to see that the fabric is not pinched between the bows, as they will chafe a hole through the top very quickly. Applying Ford top dressing will greatly improve the appearance of an old top on either an open or closed car.

### *Storing Car*

Drain the water from the radiator, then put in about a quart of anti-freeze solution to prevent freezing of any water that may possibly remain. Draw off all gasoline. Drain the old oil from the oil pan. Refill the oil pan with one gallon of fresh oil and run the engine enough to cover the different parts with oil. Remove the tires and store them. (See paragraph on "Care of Tires When Car is Stored," page 40.) Wash the car and if possible cover the body with a sheet of muslin to protect the finish.

## FORD MODEL AA 1½ TON TRUCK

### *General Instructions*

The care and general operating instructions pertaining to the car also apply to the truck with the exception that a new truck should not be driven faster than 20 to 25 miles per hour for the first 500 miles. Front tires should be inflated to 75 pounds pressure rear tires 85 pounds. The pressures should be checked every week.

### *Dual High*

The dual high transmission, which is optional equipment, gives the truck 47% more pulling power. It is operated by a double end shift pedal which extends through the floor boards. Pressing down on the rear pedal engages the dual high. Pressing down on the front pedal disengages it. (See Fig. 31.)

This shift is entirely independent of the standard transmission gear shift and can be made at any speed in which the truck is being driven whether high, second, low or reverse.

### *Engaging the Dual High*

To engage the dual high remove your foot from the accelerator. Disengage the clutch, then press down on the rear dual high clutch pedal. As soon as the dual high is engaged, reengage the clutch and press down on the accelerator until the desired driving speed is obtained.

### *Disengaging the Dual High*

To disengage the dual high remove your foot from the accelerator. Disengage the clutch and press down on the front dual high clutch pedal. As soon as the dual high is disengaged, reengage the clutch and press down on the accelerator until the desired driving speed is obtained.

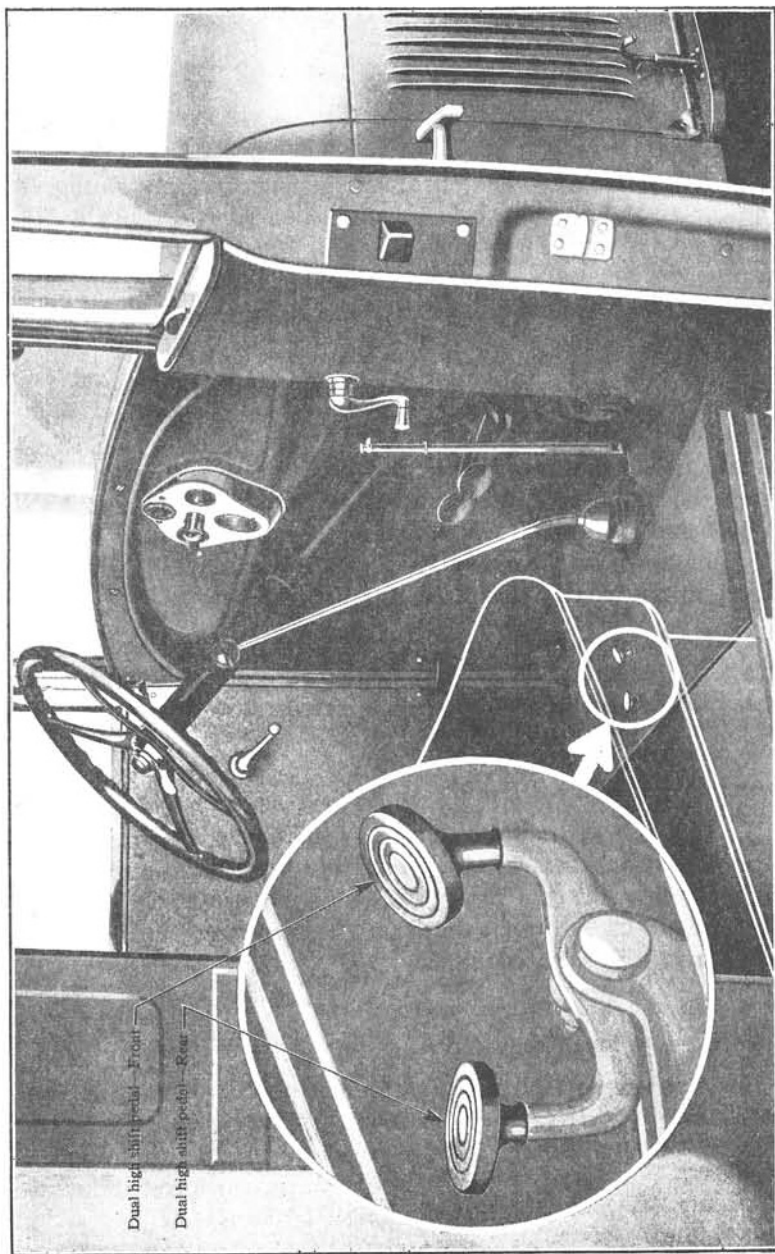

Figure 31  
Dual High Transmission Pedals



## SUMMARY OF ENGINE TROUBLES AND THEIR CAUSES

### *Engine Fails to Start:*

If starter turns engine over freely, check the following:

Ignition switch off.

Gasoline tank empty or supply shut off.

If engine is cold, mixture may not be rich enough—choke button not pulled back. See starting instructions, page 8.

Warm engine—over choking. See page 8.

Breaker points too close. The correct adjustment is .018 to .022".

Spark plug gaps too wide. Correct gap .027".

Water in sediment bulb or carburetor. See instructions on page 22.

### *Starter Fails to Turn Engine Over:*

Battery run down. A quick way to check this is to turn on the lights, and depress the starter switch. If the battery is weak the lights will go out or grow quite dim. If the battery is run down, have it recharged.

Loose or dirty battery connections—See that both the negative and positive battery terminal connections are clean and tight. These connections should be checked regularly.

### *Missing at Low Speed:*

Gas mixture too rich or too lean. See carburetor adjustment on pages 24 and 25.

Too close a gap between spark plug points. The correct gap is .027".

Breaker points improperly adjusted, badly burnt or pitted. See adjusting breaker contact points, page 28.

Fouled spark plug. Plugs should occasionally be cleaned and the gaps checked.

Water in gasoline. See instructions on cleaning sediment bulb and carburetor, page 22.

### *Missing at High Speed:*

Insufficient gasoline flowing to carburetor due to gasoline line or filter screen being partly clogged.

Gas mixture too rich or too lean. See carburetor adjustment instructions, pages 24 and 25.

Water in gasoline, drain sediment bulb and carburetor as described on page 22.

### ***Engine Stops Suddenly***

Gasoline tank empty.

Dirt in fuel line or carburetor. See instructions on page 22.

Gas mixture too lean. See adjustment of carburetor, pages 24 and 25.

### ***Engine Overheats***

Lack of water—radiator should be kept well filled.

Lack of oil—check oil level as described on page 5.

Fan belt loose or slipping. See fan belt adjustment, page 19.

Excessive carbon deposit on piston heads and in combustion chamber. This can be corrected by taking off the cylinder head and removing the carbon. (Ford dealers are equipped for this work).

Incorrect spark timing. See ignition timing page 28.

Gas mixture too rich. See adjustment of carburetor, pages 24 and 25.

Water circulation retarded by sediment in radiator. (See *Cleaning the Radiator*, page 19.)

### ***Engine Knocks***

Carbon knock—caused by a deposit of carbon in combustion chamber and on piston heads. Take off cylinder head and remove carbon.

Ignition knocks—usually occur when the car is suddenly accelerated or when ascending steep grades or travelling through heavy sand with the spark lever fully advanced. Slightly retarding the spark lever eliminates the knock. The spark should be advanced as soon as normal road conditions are encountered. For normal driving the spark lever should be carried about half way down the quadrant.

Engine overheats. Check conditions listed under "Engine Overheats."

Loose bearing. If a bearing has become loose it should be adjusted by an authorized Ford mechanic.

## INDEX TO ILLUSTRATIONS

---

	Page
Aligning Tire on Rim . . . . .	40
Brakes, Front and Rear . . . . .	42
Centering Tire on Rim . . . . .	41
Clutch Pedal Adjustment . . . . .	11
Compressor Lubricating Gun . . . . .	16
Cooling System . . . . .	18
Dual High Transmission Levers . . . . .	48
Focusing Headlamps . . . . .	35
Front View of Engine . . . . .	20
Fuel System . . . . .	23
Gear Shift Lever Positions . . . . .	8
Idling Adjustment . . . . .	25
Ignition System . . . . .	30
Installing Tire . . . . .	40
Instrument and Control Levers . . . . .	7
Mounting Tire on Rim . . . . .	40
Oiling Chart . . . . .	26-27
Oil Level Indicator . . . . .	6
Rear Axle Assembly . . . . .	38
Sectional View of Engine . . . . .	12
Sectional View of Tire . . . . .	39
Side View of Distributor . . . . .	32
Shock Absorbers (Front and Rear) . . . . .	44
Shop Layout for Focusing Headlamps . . . . .	36
Steering Gear Assembly . . . . .	37
Top View of Distributor . . . . .	29
Transmission and Clutch . . . . .	15
Water Pump Shaft . . . . .	19
Wiring Diagram . . . . .	31

# INDEX

	Page
<b>Adjustments</b>	
Brakes	42
Breaker points	28
Carburetor	24
Clutch pedal	11
Fan belt	19
Front wheel bearings	39
Generator charging rate	33
Headlamps	35
Shock absorbers	44
Spark plugs	34
<b>Ammeter</b>	34
<b>Battery Instructions</b>	32
<b>Bearings</b>	
Front wheel, adjustment of	39
<b>Brakes</b>	
Adjustment of	42
<b>Breaker Contact Points</b>	
Adjustment of	28
<b>Car</b>	
How to start	6-8
How to stop	9
How to reverse	10
Proper way to wash	46
Storing	46
<b>Carburetor</b>	
Adjustment of	24
Cleaning	22
Draining	22
<b>Chassis Lubrication Chart</b>	26-27
<b>Clutch Pedal Adjustment</b>	11
<b>Coil, Ignition</b>	34
<b>Cooling System</b>	19
<b>Diagrams, Wiring</b>	30-31
<b>Differential</b>	
Lubrication of	13
<b>Electrical System</b>	28
<b>Engine</b>	
Starting	8
Stopping	9-10
Lubrication system	13
Summary of troubles	49
<b>Fan Belt</b>	
Adjustment of	19
<b>Front Wheel Bearings</b>	
Adjustment of	39
<b>Fuel System</b>	22
<b>Gasoline Tank Capacity</b>	22
<b>Gear Shifting</b>	8-9
<b>Generator Charging Rate</b>	33
<b>Headlamps</b>	
Focusing	35
Alignment	36
Bulbs	34
<b>Ignition Timing</b>	28
<b>Ignition Coil</b>	34
<b>License Data</b>	4
<b>Lubrication Chart</b>	26-27
<b>Pedal, Clutch</b>	
Adjustment of	11
<b>Pump</b>	
Water pump packing nut	19
<b>Radiator</b>	
Capacity	5
Cleaning	19
Care of in winter	21
<b>Shifting Gears</b>	8-9
<b>Setting the Spark</b>	28
<b>Shock Absorbers</b>	44
<b>Spark Plug Adjustment</b>	34
<b>Speedometer</b>	45
<b>Starting</b>	6-8
<b>Stopping</b>	9-10
<b>Storage Battery</b>	
Care of	32-33
<b>Storing the Car</b>	46
<b>Tank, Fuel</b>	
Capacity	5
Filling	5
Draining	5
<b>Timing, Ignition</b>	28
<b>Tires</b>	
Removal	39
Mounting	40
Inflation	41
Care of	41
<b>Top</b>	
Care of	46
<b>Transmission</b>	
Lubrication of	13
<b>Water</b>	
Filling radiator	5
Putting in battery	32
In sediment bulb or carburetor	22
<b>Water Pump Packing Nut</b>	19
<b>Wiring Diagrams</b>	30-31